

Muting Modules and Dual Controllers

- Suspends safeguarding during non-hazardous times in the machine's cycle
- Allows material to move into or from the process, without tripping the muted safeguard
- Monitors hard-relay contact or PNP output safety devices
- Includes one non-safety auxiliary output
- Available in models for Type 4 (Category 4) applications
- Offers two reset options: Automatic and Monitored Manual
- Uses diverse redundancy and self-checking for control reliability
- Installs easily with DIN-rail mounting
- Connects to supplemental safeguarding devices or E-stops
- Can be used as a Dual Controller for safety devices, such as two Safety Light Screens whether the muting function is used or not



MMD-TA-11B & MMD-TA-12B Muting Modules
(MMD-TA-12B shown)



Muting Modules

Safety Category	Input Device	Supply Voltage	Inputs	Safety Outputs	Aux. Outputs	Output Rating	Output Response Time	Model
2, 3 or 4	Mechanical & Solid State	24V dc	2 NC Muteable (dual) & 2 NC SSI (dual)	2 PNP OSSD	1 PNP	0.5 amps	10 ms	MMD-TA-12B
				2 NO	1 NC	6 amp	20 ms	MMD-TA-11B

NC = Normally Closed Relay, NO = Normally Open Relay

MMD-TA-12B & MMD-TA-11B Muting Modules Specifications

System Power Requirements	<p>MMD-TA-11B: +24V dc $\pm 15\%$ @ 300 mA max (SELV/PELV) MMD-TA-12B: +24V dc $\pm 15\%$ @ 250 mA max (SELV/PELV) (not including draw of the MSSSI power, AUX, ML, M1-M4 and OSSD connections). The external voltage supply must be capable of buffering brief mains interruptions of 20 milliseconds, as specified in IEC/EN 60204-1.</p>												
Overvoltage Category	III (IEC 60664-1)												
Pollution Degree	2												
Supply Protection Circuitry	All inputs and outputs are protected from short circuit to +24V dc or dc common.												
Response Time (MSSI and SSI)	<p>MMD-TA-12B: (solid-state output) 20 milliseconds max. MMD-TA-11B: (relay output) 10 milliseconds max.</p>												
Safety Outputs	<p>MMD-TA-11B: 2 normally open contact output channels and 1 normally closed auxiliary contact output channel: Each normally open output channel is a series connection of contacts from two forced-guided (positive-guided) relays, K1-K2. The normally closed AUX contact (non-safety) 31-32 is a parallel connection of contacts from K1-K2.</p> <p>Contacts: AgNi, 5 μm gold-plated</p> <p>Low Current Rating: Caution: The 5 μm gold-plated contacts allow the switching of low current/low voltage. In these low-power applications, multiple contacts can also be switched in series (e.g., "dry switching "). To preserve the gold plating on the contacts and also guarantee reliable switching, the following values should be kept within the min. and max. ranges shown below.</p> <table style="width: 100%; margin-left: 40px;"> <tr> <td>Min. voltage: 1V ac/dc</td> <td>Max. voltage: 60V</td> </tr> <tr> <td>Min. current: 5 mA ac/dc</td> <td>Max. current: 300 mA</td> </tr> <tr> <td>Min. power: 5 mW (5 mVA)</td> <td>Max. power: 7 W (7 VA)</td> </tr> </table> <p>High Current Rating: If higher loads must be switched through one or more of the contacts, the minimum and maximum values of the contact(s) changes to:</p> <table style="width: 100%; margin-left: 40px;"> <tr> <td>Min. voltage: 15V ac/dc</td> <td>Max. voltage: 120V ac/dc</td> </tr> <tr> <td>Min. current: 30 mA ac/dc</td> <td>Max. current: 6 A</td> </tr> <tr> <td>Min. power: 0.45 W (0.45 VA)</td> <td>Max. power: 160 W (720 VA)</td> </tr> </table> <p>Mechanical life: 50,000,000 operations Electrical life: 120,000 operations (typical at 144 W/[1380 VA] switched power, resistive load)</p> <p>NOTE: Transient suppression is recommended when switching inductive loads. Install suppressors across load. Never install suppressors across output contacts</p> <p>MMD-TA-12B: Two diverse-redundant solid-state safety outputs: 24V dc, 0.5 A sourcing OSSD (output signal switching device).</p> <ul style="list-style-type: none"> ON-State voltage: $\geq V$ in-1.5V dc OFF-State voltage: 1.2V dc max. (0-1 2V dc) Max. load capacitance: 0.1 μF Max. load inductance: 10 H Leakage current: 0.50 mA max. Cable resistance: 10 Ω max. OSSD test pulse width: < 100 microseconds OSSD test pulse period: > 100 milliseconds Switching current: 0-0.5 A 	Min. voltage: 1V ac/dc	Max. voltage: 60V	Min. current: 5 mA ac/dc	Max. current: 300 mA	Min. power: 5 mW (5 mVA)	Max. power: 7 W (7 VA)	Min. voltage: 15V ac/dc	Max. voltage: 120V ac/dc	Min. current: 30 mA ac/dc	Max. current: 6 A	Min. power: 0.45 W (0.45 VA)	Max. power: 160 W (720 VA)
Min. voltage: 1V ac/dc	Max. voltage: 60V												
Min. current: 5 mA ac/dc	Max. current: 300 mA												
Min. power: 5 mW (5 mVA)	Max. power: 7 W (7 VA)												
Min. voltage: 15V ac/dc	Max. voltage: 120V ac/dc												
Min. current: 30 mA ac/dc	Max. current: 6 A												
Min. power: 0.45 W (0.45 VA)	Max. power: 160 W (720 VA)												

- Photoelectrics Sensors
- Fiber Optic Sensors
- Special Purpose Sensors
- Measurement & Inspection Sensors
- Vision
- Wireless
- Lighting & Indicators
- Safety Light Screens
- Safety Laser Scanners
- Fiber Optic Safety Systems
- Safety Controllers & Modules**
- Safety Two-Hand Control Modules
- Safety Interlock Switches
- Emergency Stop & Stop Control



- SAFETY CONTROLLERS
- SAFETY MODULES**
- E-STOP & GUARD
- UNIVERSAL SAFETY MAT
- MUTING
- SAFE SPEED
- EXTENSION
- INTERFACE

More on next page

MMD-TA-12B & MMD-TA-11B Muting Modules Specifications (cont'd)

Non-Safety Outputs	<p>Model MMD-TA-11B: Aux. output 31–32 is a parallel connection of two N.C. contacts from internal relays K1 and K2. Contact: AgNi, 5 µm gold-plated Low Current Rating: Caution: The 5 µm gold-plated contacts allow the switching of low current/low voltage. To preserve the gold plating on the contacts and also guarantee reliable switching, the following values should be kept within the min. and max. ranges shown below:</p> <table style="width: 100%; border: none;"> <tr> <td style="width: 50%;">Min. Voltage: 1V ac/dc</td> <td style="width: 50%;">Max. Voltage: 24V ac/dc</td> </tr> <tr> <td>Min. Current: 5 mA ac/dc</td> <td>Max. Current: 250 mA ac/dc</td> </tr> <tr> <td>Min. Power: 5 mW (5 mVA)</td> <td>Max. Power: 6 W (6 VA)</td> </tr> </table> <p>High Current Rating: For higher loads, the min. and max. values of the contact(s) changes to:</p> <table style="width: 100%; border: none;"> <tr> <td style="width: 50%;">Min. Voltage: 15V ac/dc</td> <td style="width: 50%;">Max. Voltage: 120V ac/dc</td> </tr> <tr> <td>Min. Current: 30 mA ac/dc</td> <td>Max. Current: 6 A</td> </tr> <tr> <td>Min. Power: 0.45 W (0.45 VA)</td> <td>Max. Power: 160 W/720 VA</td> </tr> </table> <p>Mechanical Life: 50,000,000 operations Electrical Life: >10 x 10⁶ cycles</p> <p>Model MMD-TA-12B: Z4–Z3 = Aux. 24V / 250 mA PNP output follows the two OSSD safety outputs.</p>	Min. Voltage: 1V ac/dc	Max. Voltage: 24V ac/dc	Min. Current: 5 mA ac/dc	Max. Current: 250 mA ac/dc	Min. Power: 5 mW (5 mVA)	Max. Power: 6 W (6 VA)	Min. Voltage: 15V ac/dc	Max. Voltage: 120V ac/dc	Min. Current: 30 mA ac/dc	Max. Current: 6 A	Min. Power: 0.45 W (0.45 VA)	Max. Power: 160 W/720 VA
Min. Voltage: 1V ac/dc	Max. Voltage: 24V ac/dc												
Min. Current: 5 mA ac/dc	Max. Current: 250 mA ac/dc												
Min. Power: 5 mW (5 mVA)	Max. Power: 6 W (6 VA)												
Min. Voltage: 15V ac/dc	Max. Voltage: 120V ac/dc												
Min. Current: 30 mA ac/dc	Max. Current: 6 A												
Min. Power: 0.45 W (0.45 VA)	Max. Power: 160 W/720 VA												
Status Indicators	<p>3 Status LEDs (Red, Green and Yellow): indicate waiting for Reset, Lockout, Override, and OSSD status Yellow and Green LEDs adjacent to individual inputs/interfaces indicate status (ON = active/closed)</p>												
Diagnostic Code Display	<p>Diagnostic Display is a two-digit numeric display that indicates the cause of lockout conditions and the amount of time remaining for the backdoor timer.</p>												
Muting Lamp Output	<p>A monitored or non-monitored (selectable) sinking output. If monitoring has been selected, the current draw must be 10 to 360 mA. Interconnect wire resistance < 30 Ω.</p> <p>Max. switching voltage: 30V dc Max. switching current: 360 mA Min. switching current: 10 mA</p> <p>Saturation voltage: ≤ 1.5V dc @ 10 mA; ≤ 5V dc @ 360 mA</p>												
Controls and Adjustments	<p>All configured on two redundant banks of DIP switches:</p> <ul style="list-style-type: none"> Manual/auto reset One-way/two-way muting Monitored/non-monitored mute lamp output One-channel/two-channel/no EDM Backdoor timer Mute on power-up enable 												
Inputs	<p>The MSSSI and the SSI can be interfaced with external safety devices that have either hard contact outputs or solid-state sourcing outputs.</p> <p>When connecting the MSSSI (S11-S12, S21-S22) or SSI (X5-X6, X7-X8) inputs to safety relay outputs or hard contacts, these contacts must be capable of switching 15 to 30 V dc at 10-50 mA.</p> <p>Operating Range for MSSSI and SSI Inputs</p> <p>OFF State: -3V to +5V, 0 to 2 mA ON State: 15-30V, 10-50 mA</p> <p>Muteable Safety Stop Interface (MSSSI) This input consists of two channels (MSSSI-A and MSSSI-B), and can be muted when the requirements for a mute cycle have been met. When muted, the OSSDs remain ON, independent of the MSSSI status. If not muted, when either or both channels open, the OSSD outputs will go OFF. <i>Maximum external resistance per channel must not exceed 400 Ω.</i></p> <p>Safety Stop Interface (SSI) This input consists of two channels (SSI-A and SSI-B), and is always active. When one or both channels open, the OSSD Outputs will go OFF. <i>Maximum external resistance per channel must not exceed 400 Ω.</i></p>												
External Device Monitoring (EDM)	<p>Two pairs of terminals are provided to monitor the state of external devices controlled by the OSSD outputs. Each device must be capable of switching 15-30V dc at 10-50 mA.</p>												
Muting Device Inputs	<p>The muting devices work in pairs (M1 and M2, M3 and M4) and are required to be “closed” within 3 seconds of each other (simultaneity requirement/synchronous actuation) to initiate a mute (assuming all other conditions are met). Each muting device must be capable of switching 15-30V dc at 10-50 mA.</p>												
Mute Enable Input	<p>The mute enable input must have +24V dc applied in order to start a mute; opening this input after mute has begun has no effect. The switching device must be capable of switching 15-30V dc at 10-50 mA.</p>												

More
on next
page

MMD-TA-12B & MMD-TA-11B Muting Modules Specifications (cont'd)	
Override Inputs	The two-channel inputs must be closed within 3 seconds of each other (simultaneity/synchronous action requirement) and held closed during the 30-second Override. To initiate a subsequent Override, open both channels, wait 3 seconds, and then re-close both channels (within 3 seconds). The switching devices must be capable of switching 15-30V dc at 10-50 mA.
Reset Input	Terminals must be closed for a minimum of 0.25 seconds and not more than 2.0 seconds in order to guarantee a reset. The switching device must be capable of switching 15-30V dc at 10-50 mA.
Mounting	Mounts to standard 35 mm DIN rail track. Safety Module must be installed inside an enclosure rated NEMA 3 (IP54), or better.
Vibration Resistance	10 to 55 Hz @ 0.35 mm displacement per IEC 68-2-6.
Construction	Polycarbonate housing
Connections	Removable terminal blocks
Environmental Rating	NEMA 1; IP20
Operating Conditions	Temperature range: 0° to +50° C Relative humidity: 95% (non-condensing)
Design Standards	Designed to comply with Safety Category 4 per SIL 3 (IEC 61508); SIL CL3 (IEC 62061); Category 4, Performance Level (PL) e (ISO 13849-1)
Certifications	 
Wiring Diagrams	MMD-TA-12B: WD052, WD054, WD055 (pp. 810-813) MMD-TA-11B: WD053 (p. 811)

- Photoelectrics Sensors
- Fiber Optic Sensors
- Special Purpose Sensors
- Measurement & Inspection Sensors
- Vision
- Wireless
- Lighting & Indicators
- Safety Light Screens
- Safety Laser Scanners
- Fiber Optic Safety Systems
- Safety Controllers & Modules**
- Safety Two-Hand Control Modules
- Safety Interlock Switches
- Emergency Stop & Stop Control

- SAFETY CONTROLLERS
- SAFETY MODULES**
- E-STOP & GUARD
- UNIVERSAL
- SAFETY MAT
- MUTING**
- SAFE SPEED
- EXTENSION
- INTERFACE

WD052



Page 540

Models

- MMD-TA-12B

**MMD-TA-12B
Terminal Locations**

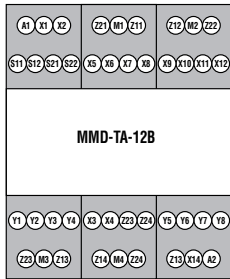

MMD-TA-12B DIN-Rail Muting Module

2-Channel EDM with Interface Model

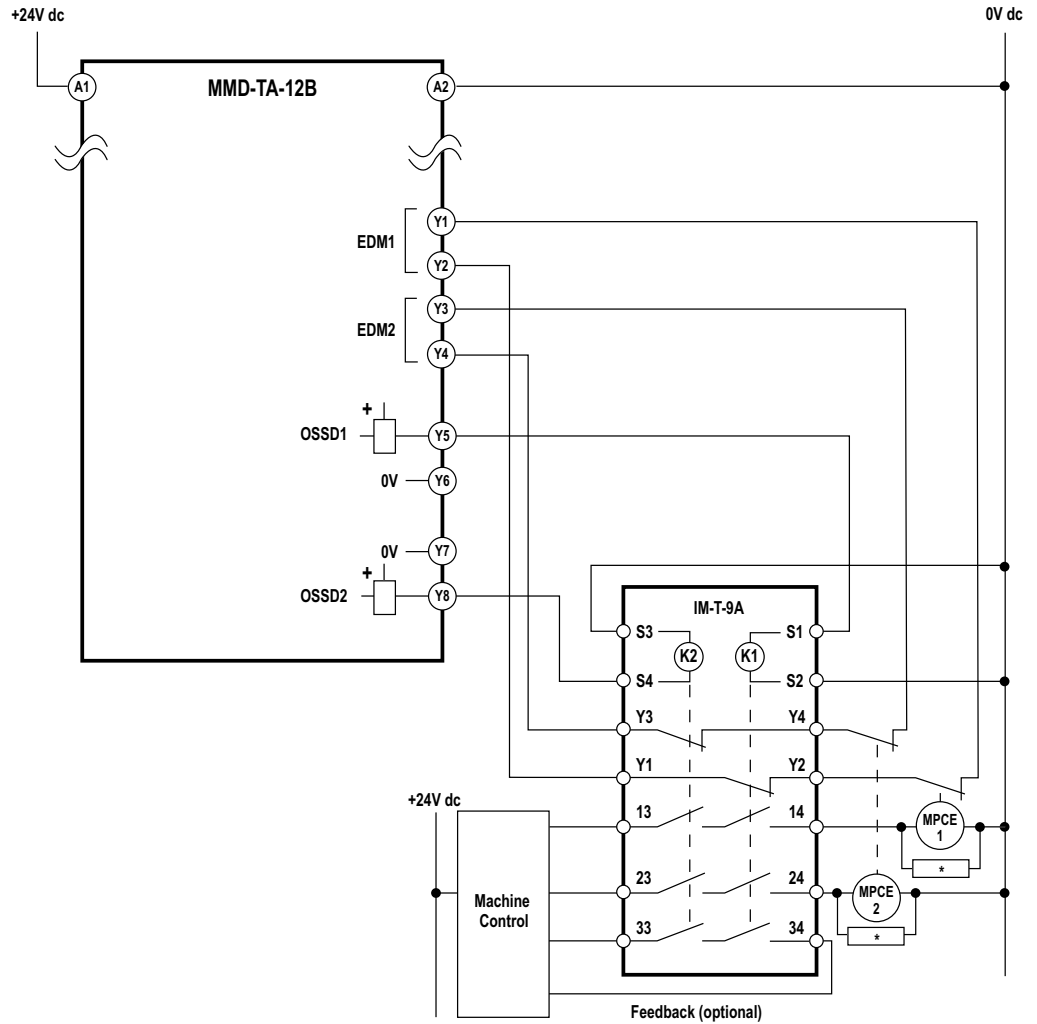

* Arc Suppressors. See manual for specific warnings.

Wiring diagrams are for information only. See appropriate manuals for all specific warnings, cautions and information for use.

More on next page

MMD-TA-12B DIN-Rail Muting Module

1-Channel EDM with Interface Model



Page 540

Models

- MMD-TA-12B

MMD-TA-12B Terminal Locations

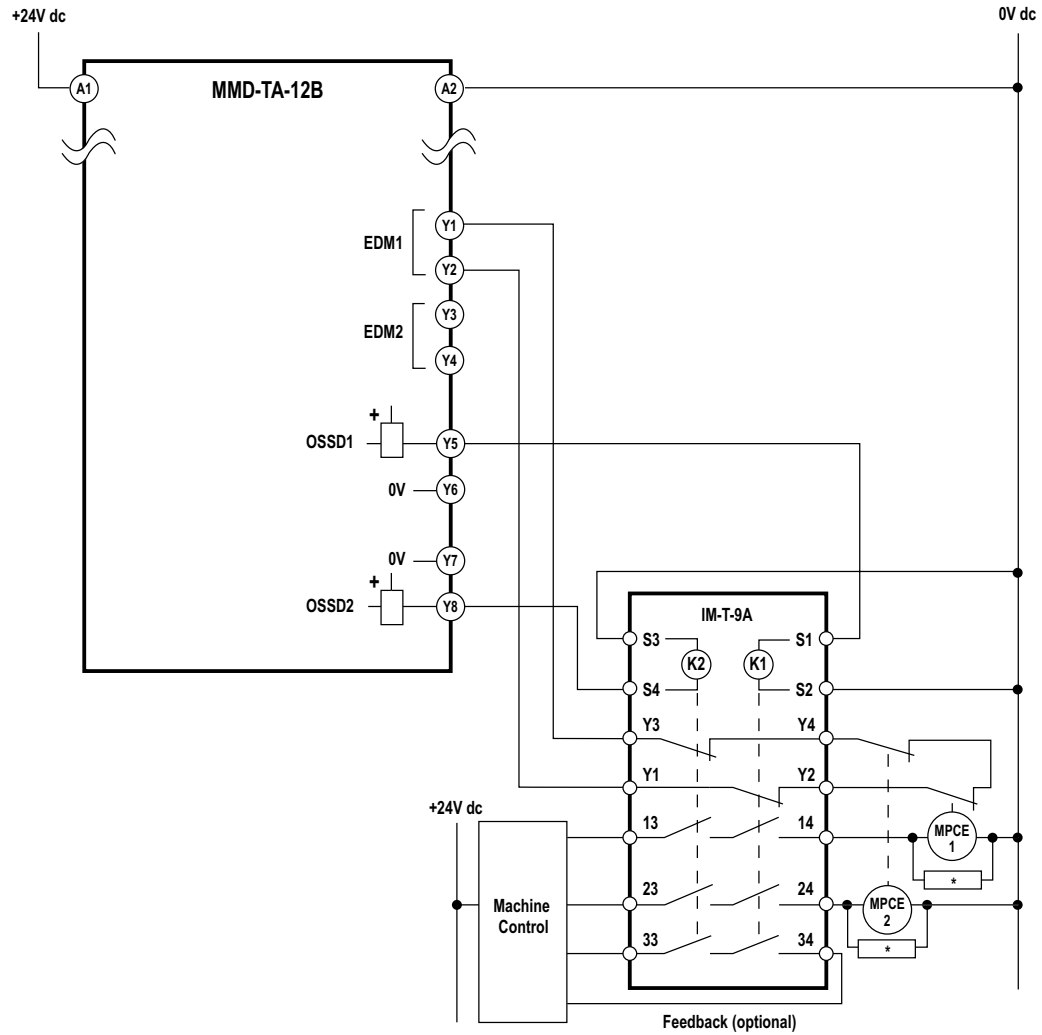
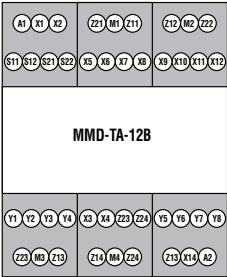

Wiring diagrams are for information only. See appropriate manuals for all specific warnings, cautions and information for use.

More on next page

- Accessories
- Reference
- Hookups
- Wiring Diagrams
- Glossary
- International Reps

* Arc Suppressors. See manual for specific warnings.

WD054

SSM Safe Speed Monitor Module

SSM-FM-11.. to Two PNP Sensors





Page 544

Models

- SSM-FA-11A10
- SSM-FA-11A20

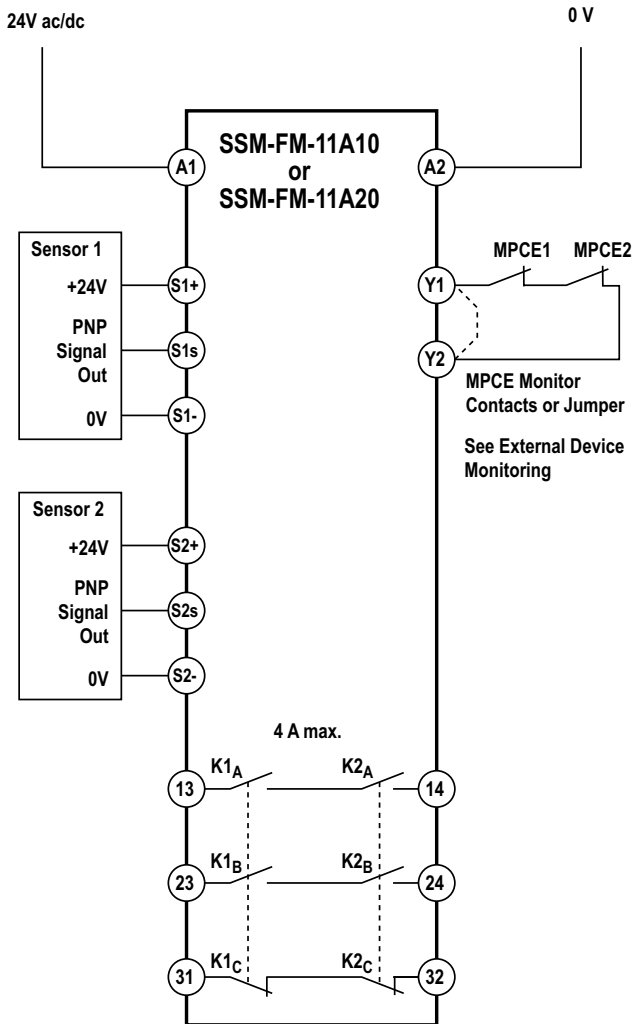
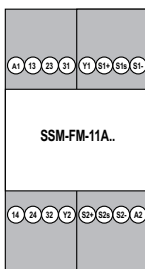
SSM-FA-11A.. Terminal Locations



 Wiring diagrams are for information only. See appropriate manuals for all specific warnings, cautions and information for use.

More on next page

WD055

EM-T-7A Extension Module

EM-T-7A 1-Channel Control, 1-Channel EDM



Page 546

Models

- EM-T-7A

EM-T-7A

Terminal Locations

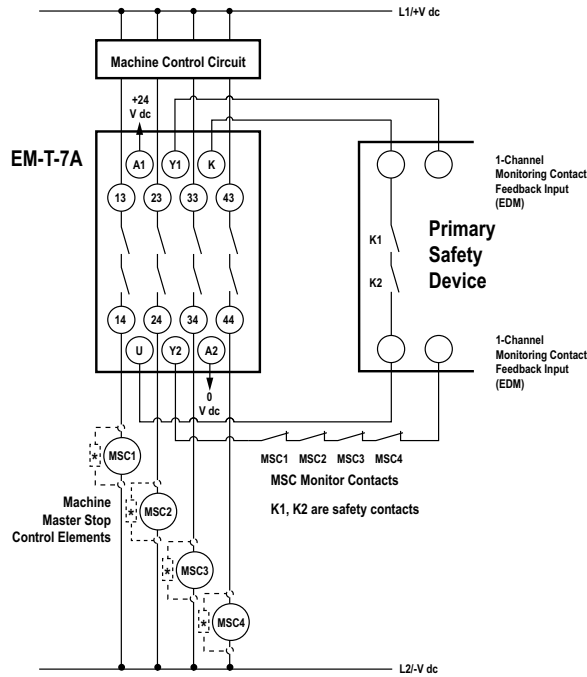

* Arc Suppressors. See manual for specific warnings.

Wiring diagrams are for information only. See appropriate manuals for all specific warnings, cautions and information for use.

Accessories

Reference

Hookups

Wiring Diagrams

Glossary

International Reps

WD056

EM-T-7A Extension Module

EM-T-7A 2-Channel Control, 1-Channel EDM

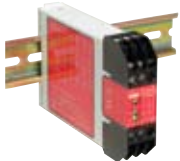

Page 546

Models

- EM-T-7A

EM-T-7A

Terminal Locations

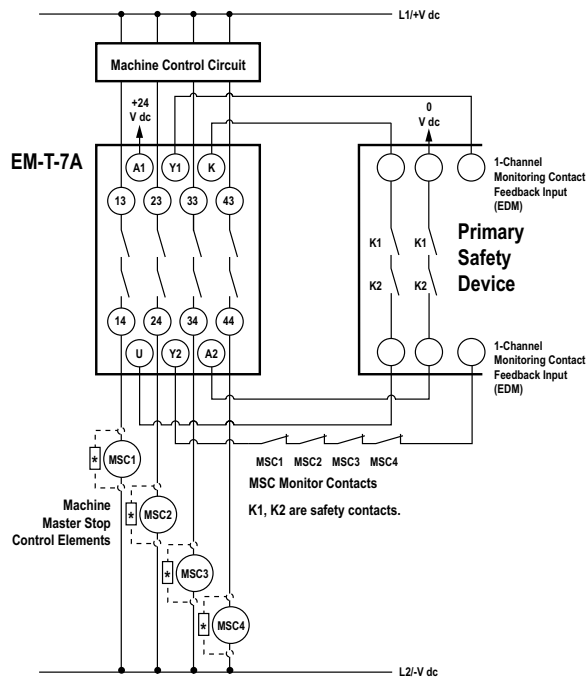

* Arc Suppressors. See manual for specific warnings.

Wiring diagrams are for information only. See appropriate manuals for all specific warnings, cautions and information for use.

More on next page